

Package leaflet: Information for the user

ReFacto AF[®] 250 IU powder and solvent for solution for injection in pre-filled syringe
ReFacto AF[®] 500 IU powder and solvent for solution for injection in pre-filled syringe
ReFacto AF[®] 1000 IU powder and solvent for solution for injection in pre-filled syringe
ReFacto AF[®] 2000 IU powder and solvent for solution for injection in pre-filled syringe
ReFacto AF[®] 3000 IU powder and solvent for solution for injection in pre-filled syringe

moroctocog alfa (recombinant human coagulation factor VIII)

Read all of this leaflet carefully before you start using this medicine because it contains important information for you.

- Keep this leaflet. You may need to read it again.
- If you have further questions, please ask your doctor or pharmacist.
- This medicine has been prescribed for you only. Do not pass it on to others. It may harm them, even if their signs of illness are the same as yours.
- If you get any side effects, talk to your doctor or pharmacist. This includes any possible side effects not listed in this leaflet. See section 4.

What is in this leaflet:

1. What ReFacto AF is and what it is used for
2. What you need to know before you use ReFacto AF
3. How to use ReFacto AF
4. Possible side effects
5. How to store ReFacto AF
6. Contents of the pack and other information

1. What ReFacto AF is and what it is used for

ReFacto AF contains the active substance moroctocog alfa, human coagulation factor VIII. Factor VIII is necessary for the blood to form clots and stop bleedings. In patients with haemophilia A (inborn factor VIII deficiency), it is missing or not working properly.

ReFacto AF is used for the treatment and prevention of bleeding (prophylaxis) in adults and children of all ages (including newborns) with haemophilia A.

2. What you need to know before you use ReFacto AF

Do not use ReFacto AF

- if you are allergic to moroctocog alfa or any of the other ingredients of this medicine (listed in section 6).
- if you are allergic to hamster proteins.

If you are unsure about this, ask your doctor.

Warnings and precautions

Talk to your doctor or pharmacist before using ReFacto AF

- if you experience allergic reactions. Some of the signs of allergic reactions are difficulty in breathing, shortness of breath, swelling, hives, itching, tightness of the chest, wheezing, and low blood pressure. Anaphylaxis is a severe allergic reaction that can cause difficulty in swallowing

and/or breathing, red or swollen face and/or hands. If any of these signs occur, stop the infusion immediately and contact a doctor or seek immediate emergency care. In case of severe allergic reactions, alternative therapy must be considered.

- the formation of inhibitors (antibodies) is a known complication that can occur during treatment with all factor VIII medicines. These inhibitors, especially at high levels, stop the treatment working properly and you or your child will be monitored carefully for the development of these inhibitors. If your or your child's bleeding is not being controlled with ReFacto AF, tell your doctor immediately.
- if your bleeding does not stop as expected and contact your doctor or seek immediate emergency care.

Other medicines and ReFacto AF

Tell your doctor or pharmacist if you are using, have recently used or might use any other medicines.

Pregnancy, breast-feeding and fertility

If you are pregnant or breast-feeding, think you may be pregnant or are planning to have a baby, ask your doctor or pharmacist for advice before using this medicine.

Driving and using machines

ReFacto AF has no influence on the ability to drive or use machines.

ReFacto AF contains sodium

After reconstitution, ReFacto AF contains 1.27 mmol (or 29 mg) sodium (main component of cooking/table salt) per pre-filled syringe. This is equivalent to 1.5% of the recommended maximum daily dietary intake of sodium for an adult. Depending on your body weight and your dose of ReFacto AF, you could receive multiple pre-filled syringes. This should be taken into consideration if you are on a low salt diet.

3. How to use ReFacto AF

Always use this medicine exactly as your doctor has told you. Check with your doctor or pharmacist if you are not sure.

Treatment with ReFacto AF should be started by a doctor who is experienced in the care of patients with haemophilia A. Your doctor will decide the dose of ReFacto AF you will receive. This dose and duration will depend upon your individual needs for replacement factor VIII therapy. ReFacto AF is given by injection into a vein lasting several minutes. Patients or their carers can give injections of ReFacto AF, provided that they have been trained appropriately.

During your treatment, your doctor may decide to change the dose of ReFacto AF you receive. Consult with your health care provider before you travel. You should bring enough of your factor VIII product for anticipated treatment when travelling.

It is recommended that every time you use ReFacto AF, you record the name on the carton and batch number of the product. You can use one of the peel-off labels found on the pre-filled syringe to document the batch number in your diary or for reporting any side effects.

Reconstitution and administration

The procedures below are provided as guidelines for the reconstitution and administration of ReFacto AF provided in a pre-filled syringe. Patients should follow the specific reconstitution and administration procedures provided by their doctors.

ReFacto AF is administered by intravenous (IV) infusion after reconstitution. The pre-filled syringe consists of 2 chambers, one chamber contains the ReFacto AF lyophilised powder and the other chamber contains the solvent [sodium chloride 9 mg/ml (0.9%) solution]. For the purposes of these instructions, this device will be referred to as a pre-filled syringe.

Use only the pre-filled syringe provided in the box for reconstitution. Other sterile disposable syringes may be used for administration.

ReFacto AF should not be mixed with other infusion solutions.

Note: If you need to use more than one pre-filled syringe of ReFacto AF per infusion, each syringe should be reconstituted according to the specific directions. A separate 10 cc or larger luer lock syringe (not included in this kit) may be used to draw back the reconstituted contents of each syringe (see **Additional Instructions**)

Preparation

1. Always wash your hands before performing the following procedures.
2. Aseptic technique (meaning clean and germ-free) should be used during the reconstitution procedure.
3. All components used in the reconstitution and administration of this product should be used as soon as possible after opening their sterile containers, to minimise unnecessary exposure to the air.

Reconstitution

1. Allow the pre-filled syringe to reach room temperature.
2. Remove the contents of the ReFacto AF pre-filled syringe kit and place on a clean surface, making sure you have all the supplies you will need.
3. Grasp the plunger rod as shown in the following diagram. Screw the plunger rod firmly into the opening in the finger rest of the ReFacto AF pre-filled syringe by pushing and turning clockwise firmly until resistance is felt (approximately 2 turns).

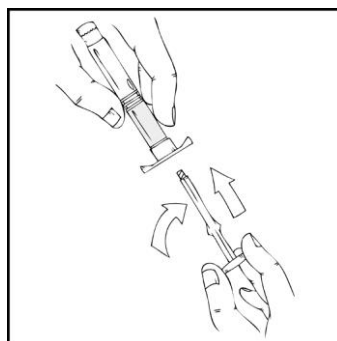

Throughout the reconstitution process, it is important to keep the ReFacto AF pre-filled syringe upright (with the white powder above the clear solution) to prevent possible leakage.

4. Holding the pre-filled syringe upright, remove the white tamper-evident seal by bending the seal right to left (or a gentle rocking motion) to break the perforation of the cap and expose the grey rubber tip cap of the ReFacto AF pre-filled syringe.

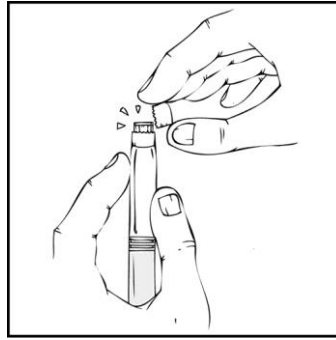

5. Remove the protective blue vented sterile cap from its packaging.

Whilst continuing to hold the ReFacto AF pre-filled syringe upright, remove the grey rubber tip cap and replace it with the protective blue vented cap. This vented cap has tiny holes that allow air to escape in order to prevent pressure build-up. Avoid touching the open end of the syringe or the protective blue vented cap.

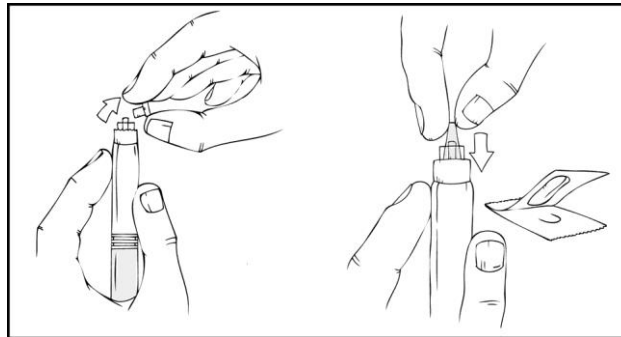

6. **Gently and slowly** advance the plunger rod by pushing until the two plungers inside the pre-filled syringe meet, and all of the solvent is transferred to the top chamber containing the ReFacto AF powder.

Note: To prevent the escape of fluid from the tip of the syringe, do not push the plunger rod with excessive force.

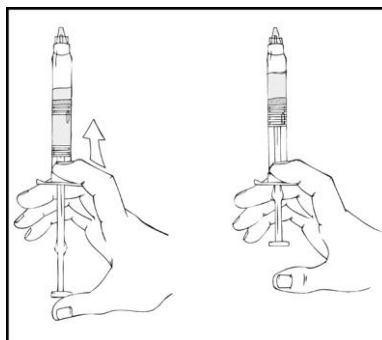

7. With the ReFacto AF pre-filled syringe remaining upright, swirl **gently** several times until the powder is dissolved.

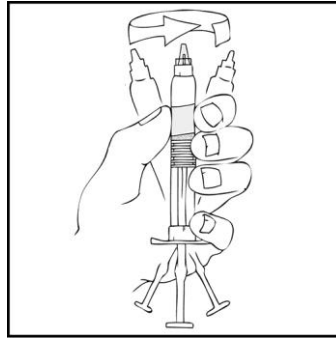

Look at the final solution to check for particulate matter or discoloration. The solution should appear clear to slightly opalescent and colourless. Discard the pre-filled syringe if visible particulate matter or discoloration is observed.

8. Continuing to hold the ReFacto AF pre-filled syringe in an upright position, slowly advance the plunger rod until most, but not all, of the air is removed from the (top) chamber.

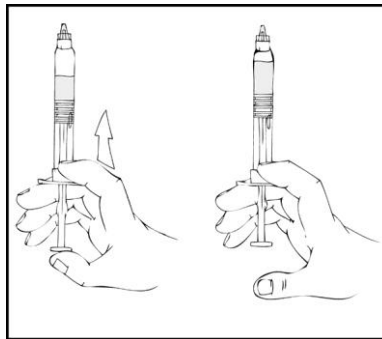

ReFacto AF should be infused within 3 hours after either reconstitution or removal of the grey tip cap from the pre-filled syringe.

If you are not going to use the ReFacto AF solution immediately, you should store the syringe in an upright position, with the protective blue vented cap on the pre-filled syringe until you are ready to infuse. The reconstituted solution may be stored at room temperature for up to 3 hours. If you have not used it within 3 hours, throw it away.

Administration (Intravenous Infusion)

Your doctor or other healthcare professional should teach you how to infuse ReFacto AF. Once you learn how to self-infuse, you can follow the instructions in this Package Leaflet.

ReFacto AF is administered by intravenous (IV) infusion after reconstitution of the powder with the solvent (0.9% sodium chloride). Once reconstituted, ReFacto AF should be inspected for particulate matter and discoloration prior to administration.

ReFacto AF should be administered using the infusion set included in the kit, unless otherwise advised by your doctor or other healthcare professional.

1. Remove the protective blue vented cap and firmly attach the intravenous infusion set provided onto the ReFacto AF pre-filled syringe.

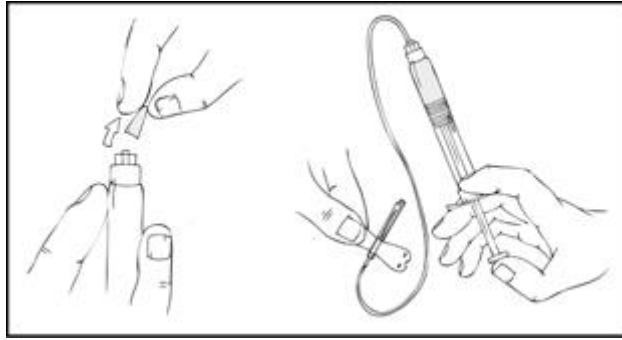

2. Apply a tourniquet and prepare the injection site by wiping the skin well with an alcohol swab provided in the kit.

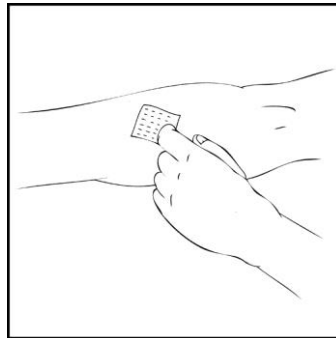

3. Remove the protective needle cover and insert the butterfly needle of the infusion set tubing into your vein, as instructed by your doctor or other healthcare professional. Remove the tourniquet. The reconstituted ReFacto AF product should be injected intravenously over several minutes. Your doctor may change your recommended infusion rate to make the infusion more comfortable. Discuss your intravenous infusion procedure with your doctor or other healthcare professional. Do not attempt self-infusion unless properly trained.

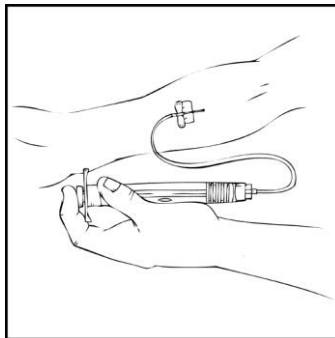

Reconstituted ReFacto AF must not be administered in the same tubing or container with other medicinal products.

4. After infusing ReFacto AF, remove the infusion set and discard. The amount of drug product left in the infusion set will not affect your treatment.

Note: Please dispose of all unused solution, the empty pre-filled syringe, and the used medical supplies in an appropriate container for throwing away medical waste, as these materials may hurt others if not disposed of properly.

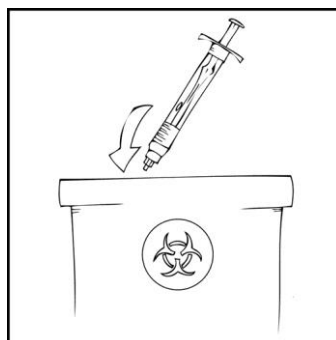

It is recommended to record the lot number from the ReFacto AF pre-filled syringe label every time you use ReFacto AF. You can use the peel-off label found on the ReFacto AF pre-filled syringe to record the lot number.

Additional Instructions:

Multiple ReFacto AF in Pre-filled Syringe Reconstitution to a 10 cc or Larger Luer Lock Syringe (10 cc or larger luer lock syringes not provided)

The instructions below are for the use of multiple ReFacto AF pre-filled syringe kits with a 10 cc or larger luer lock syringe.

1. Reconstitute all ReFacto AF pre-filled syringes according to instructions shown above in the reconstitution directions (see Reconstitution and Administration).

Holding the ReFacto AF pre-filled syringe in an upright position, slowly advance the plunger rod until most, but not all, of the air is removed from the drug product chamber.

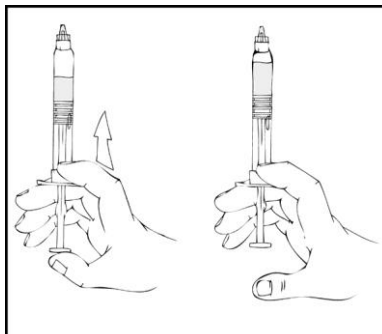

2. Remove the luer-to-luer syringe connector from its package (luer-to-luer syringe connectors are not provided).
3. Connect a sterile 10 cc or larger luer lock syringe to one opening (port) in the syringe connector and the ReFacto AF pre-filled syringe to the remaining open port on the opposite end.

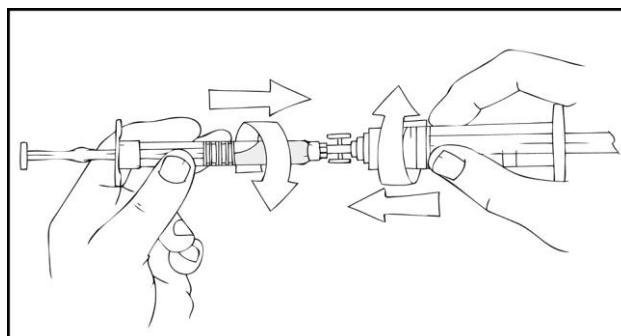

4. With the ReFacto AF pre-filled syringe on top, slowly depress the plunger rod until the contents empty into the 10 cc or larger luer lock syringe.

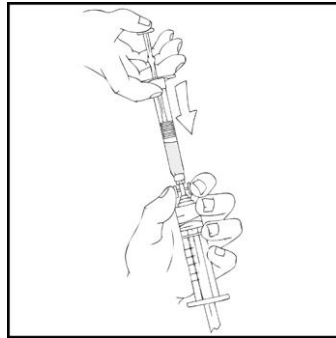

5. Remove the empty ReFacto AF pre-filled syringe and repeat procedures 3 and 4 above for any additional reconstituted syringes.
6. Remove the luer-to-luer syringe connector from the 10 cc or larger luer lock syringe and attach the infusion set, as described above in the directions for administration of the pre-filled syringe [see Administration (Intravenous Infusion)].

Note: Please dispose of all unused solution, the empty pre-filled syringe, and the used medical supplies in an appropriate container for throwing away medical waste, as these materials may hurt others if not disposed of properly.

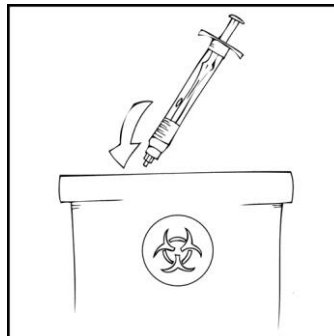

If you use more ReFacto AF than you should

Check with your doctor or pharmacist.

If you stop using ReFacto AF

Do not stop using ReFacto AF without consulting your doctor.

If you have any further questions on the use of this medicine, ask your doctor or pharmacist.

4. Possible side effects

Like all medicines, this medicine can cause side effects, although not everybody gets them.

Allergic reactions

If **severe, sudden allergic reactions** (anaphylactic) occur, the infusion **must be stopped immediately**. You must **contact your doctor immediately** if you have any of the following early symptoms of allergic reactions:

- rash, hives, wheals, generalised itching
- swelling of lips and tongue
- difficulty in breathing, wheezing, tightness in the chest
- general feeling of being unwell
- dizziness and loss of consciousness

Severe symptoms, including difficulty in breathing and (nearly) fainting, require prompt emergency treatment. Severe, sudden allergic (anaphylactic) reactions are uncommon (may affect up to 1 in 100 people).

Inhibitor development

For children not previously treated with factor VIII medicines, inhibitor antibodies (see section 2) may form very commonly (more than 1 in 10 patients); however patients who have received previous treatment with factor VIII (more than 150 days of treatment) the risk is uncommon (less than 1 in 100 patients). If this happens, your or your child's medicines may stop working properly and you or your child may experience persistent bleeding. If this happens, you should contact your doctor immediately.

Very common side effects (may affect more than 1 in 10 people)

- inhibitor development for patients who have never been previously treated with factor VIII products
- headache
- cough
- joint pain
- fever

Common side effects (may affect up to 1 in 10 people)

- bleeding
- dizziness
- decreased appetite, diarrhoea, vomiting, stomach pain, nausea
- hives, rash, itching
- muscular pain
- chills, catheter site reaction
- certain blood tests may show an increase in antibodies to factor VIII

Uncommon side effects (may affect up to 1 in 100 people)

- inhibitor development for patients who have been previously treated with factor VIII products (less than 1 in 100 patients)
- severe allergic reaction
- numbness, sleepiness, altered taste
- chest pain, rapid heart beat, palpitations
- low blood pressure, pain and redness of veins associated with a blood clot, flushing
- shortness of breath
- excessive sweating
- weakness, injection site reactions including pain
- slight increase in heart enzymes
- increased liver enzymes, increased bilirubin

Reporting of side effects

If you get any side effects, talk to your doctor or pharmacist. This includes any possible side effects not listed in this leaflet. You can also report side effects directly via the Yellow Card Scheme website: www.mhra.gov.uk/yellowcard or search for MHRA Yellow Card in the Google Play or Apple App Store. By reporting side effects you can help provide more information on the safety of this medicine.

5. How to store ReFacto AF

Keep this medicine out of the sight and reach of children.

Do not use this medicine after the expiry date which is stated on the outer carton and pre-filled syringe label after EXP. The expiry date refers to the last day of that month.

Store and transport refrigerated (2°C – 8°C). Do not freeze, in order to prevent damage to the pre-filled syringe.

For your convenience, the medicine can be removed from such storage for one single period of maximum 3 months at room temperature (up to 25°C). At the end of this room temperature storage period, the product must not be put back in the refrigerator, but must be used or discarded. Record on the outer carton the date ReFacto AF pre-filled syringe is removed from the refrigerator and set at room temperature (up to 25°C).

Keep the pre-filled syringe in the outer carton in order to protect from light.

Use the reconstituted solution within 3 hours of reconstitution or removal of the grey tip cap.

The solution will be clear to slightly opalescent and colourless. Do not use this medicine if you notice that it is cloudy or contains visible particles.

Do not throw away any medicines via wastewater or household waste. Ask your pharmacist how to throw away medicines you no longer use. These measures will help protect the environment.

6. Contents of the pack and other information

What ReFacto AF contains

- The active substance is moroctocog alfa (recombinant coagulation factor VIII). Each pre-filled syringe of ReFacto AF contains nominally 250, 500, 1000, 2000, or 3000 IU of moroctocog alfa.
A solvent [sodium chloride 9 mg/ml (0.9%) solution for injection] is included within the ReFacto AF pre-filled syringe for reconstituting moroctocog alfa.
- The other ingredients are sucrose, calcium chloride dihydrate, L-histidine, polysorbate 80 and sodium chloride (see section 2 “ReFacto AF contains sodium”).
- After reconstitution with the supplied solvent [sodium chloride 9 mg/ml (0.9%) solution], the prepared solution for injection contains either 62.5, 125, 250, 500 or 750 IU of moroctocog alfa per ml, respectively (based on the strength of moroctocog alfa, i.e., 250, 500, 1000, 2000, or 3000 IU).

What ReFacto AF looks like and contents of the pack

ReFacto AF is provided as a powder and solvent for solution for injection in a pre-filled syringe that contains the ReFacto AF powder in the top chamber and the solvent [sodium chloride 9 mg/ml (0.9%) solution] in the bottom chamber.

The contents of the pack are:

- one pre-filled syringe containing moroctocog alfa 250, 500, 1000, 2000, or 3000 IU powder and solvent, 4 ml sterile sodium chloride 9 mg/ml (0.9 %) solution for injection for reconstitution
- one plunger rod
- one protective blue vented sterile cap

- one sterile infusion set
- two alcohol swabs
- one plaster
- one gauze pad

Marketing Authorisation Holder

Pfizer Limited
Ramsgate road
Sandwich
Kent
CT13 9NJ
United Kingdom

Manufacturer

Wyeth Farma S.A.
Autovia del Norte A-1 Km 23
Desvio Algete Km 1
28700 San Sebastian de los Reyes
Madrid
Spain

For any information about this medicine, please contact:

Medical Information, Pfizer Ltd, Walton Oaks, Dorking Road, Tadworth, Surrey, KT20 7NS.
Telephone 01304 616161

This leaflet was last revised in 01/2021

Ref: RF 14_0