

Package leaflet: Information for the user

Rotarix oral suspension in squeezable tube rotavirus vaccine, live

Read all of this leaflet carefully before your child receives this vaccine because it contains important information for you.

- Keep this leaflet. You may need to read it again.
- If you have any further questions, ask your doctor or pharmacist.
- This vaccine has been prescribed for your child only. Do not pass it on to others.
- If you get any side effects, talk to your doctor or pharmacist. This includes any possible side effects not listed in this leaflet. See section 4.

What is in this leaflet

1. What Rotarix is and what it is used for
2. What you need to know before your child receives Rotarix
3. How Rotarix is given
4. Possible side effects
5. How to store Rotarix
6. Contents of the pack and other information

1. What Rotarix is and what it is used for

Rotarix is a viral vaccine, containing live, attenuated human rotavirus, that helps to protect your child, from the age of 6 weeks, against gastro-enteritis (diarrhoea and vomiting) caused by rotavirus infection.

How Rotarix works

Rotavirus infection is the most common cause of severe diarrhoea in infants and young children. Rotavirus is easily spread from hand-to-mouth due to contact with stools from an infected person. Most children with rotavirus diarrhoea recover on their own. However, some children become very ill with severe vomiting, diarrhoea and life-threatening loss of fluids that requires hospitalisation.

When a person is given the vaccine, the immune system (the body's natural defences) will make antibodies against the most commonly occurring types of rotavirus. These antibodies protect against disease caused by these types of rotavirus.

As with all vaccines, Rotarix may not completely protect all people who are vaccinated against the rotavirus infections it is intended to prevent.

2. What you need to know before your child receives Rotarix

Rotarix should not be given

- if your child has previously had any allergic reaction to rotavirus vaccines or any of the other ingredients of this vaccine (listed in section 6). Signs of an allergic reaction may include itchy skin rash, shortness of breath and swelling of the face or tongue.
- if your child has previously had intussusception (a bowel obstruction in which one segment of bowel becomes enfolded within another segment).
- if your child was born with a malformation of the gut that could lead to intussusception.
- if your child has a rare inherited illness which affects their immune system called Severe Combined Immunodeficiency (SCID).

- if your child has a severe infection with a high temperature. It might be necessary to postpone the vaccination until recovery. A minor infection such as a cold should not be a problem, but talk to your doctor first.
- if your child has diarrhoea or is vomiting. It might be necessary to postpone the vaccination until recovery.

Warnings and precautions

Talk to your doctor/health care professional before your child receives Rotarix if:

- he/she has a close contact such as a household member who has a weakened immune system, e.g., a person with cancer or who is taking medicines that may weaken the immune system.
- he/she has any disorder of the gastrointestinal system.
- he/she has not been gaining weight and growing as expected.
- he/she has any disease or is taking any medicine which reduces his/her resistance to infection or if his/her mother has taken during pregnancy any medicine that may weaken the immune system.

After your child has received Rotarix, contact a doctor/health care professional right away if your child experiences severe stomach pain, persistent vomiting, blood in stools, a swollen belly and/or high fever (see also section 4 “Possible side effects”).

As always, please take care to wash your hands thoroughly after changing soiled nappies.

Other medicines and Rotarix

Tell your doctor if your child is taking, has recently taken or might take any other medicines or has recently received any other vaccine.

Rotarix may be given at the same time your child receives other normally recommended vaccines, such as diphtheria, tetanus, pertussis (whooping cough), *Haemophilus influenzae* type b, oral or inactivated polio, hepatitis B vaccines as well as pneumococcal and meningococcal serogroup C conjugate vaccines.

Rotarix with food and drink

There are no restrictions on your child’s consumption of food or liquids, either before or after vaccination.

Breast-feeding

Based on evidence generated in clinical trials, breast-feeding does not reduce the protection against rotavirus gastro-enteritis afforded by Rotarix. Therefore, breast-feeding may be continued during the vaccination schedule.

Rotarix contains sucrose

If you have been told by your doctor that the child being vaccinated has an intolerance to some sugars, contact your doctor before receiving this vaccine.

3. How Rotarix is given

The doctor or nurse will administer the recommended dose of Rotarix to your child. The vaccine (1.5 ml liquid) will be given **orally**. Under no circumstance should this vaccine be administered by injection.

Your child will receive two doses of the vaccine. Each dose will be given on a separate occasion with an interval of at least 4 weeks between the two doses. The first dose may be given from the age of 6 weeks. The two doses of the vaccine must have been given by the age of 24 weeks, although they should preferably have been given before 16 weeks of age.

Rotarix may be given according to the same vaccination course to infants who were born prematurely, provided that the pregnancy had lasted at least 27 weeks.

In case your child spits out or regurgitates most of the vaccine dose, a single replacement dose may be given at the same vaccination visit.

When Rotarix is given to your child for the first dose, it is recommended that your child also receives Rotarix (and not another rotavirus vaccine) for the second dose.

It is important that you follow the instructions of your doctor or nurse regarding return visits. If you forget to go back to your doctor at the scheduled time, ask your doctor for advice.

4. Possible side effects

Like all medicines, this vaccine can cause side effects, although not everybody gets them.

The following side effects may happen with this vaccine:

- ◆ Common (These may occur with up to 1 in 10 doses of the vaccine):
 - diarrhoea
 - irritability
- ◆ Uncommon (These may occur with up to 1 in 100 doses of the vaccine):
 - abdominal pain (see also below for signs of very rare side effects of intussusception)
 - flatulence
 - inflammation of the skin

Side effects that have been reported during marketed use of Rotarix include:

- Very rare: hives (urticaria)
- Very rare: intussusception (part of the intestine gets blocked or twisted). The signs may include severe stomach pain, persistent vomiting, blood in stools, a swollen belly and/or high fever. **Contact a doctor/health care professional right away if your child experiences one of these symptoms.**
- blood in stools
- in babies born very prematurely (at or before 28 weeks of gestation) longer gaps than normal between breaths may occur for 2-3 days after vaccination.
- children with a rare inherited illness called Severe Combined Immunodeficiency (SCID) may have an inflamed stomach or gut (gastroenteritis) and pass the vaccine virus in their stools. The signs of gastroenteritis may include feeling sick, being sick, stomach cramps or diarrhoea.

Reporting of side effects

If your child gets any of the side effects, talk to your doctor or pharmacist. This includes any possible side effects not listed in this leaflet. You can also report side effects directly via

United Kingdom

Yellow Card Scheme

Website: www.mhra.gov.uk/yellowcard or search for MHRA Yellow Card in the Google Play or Apple App Store

By reporting side effects you can help provide more information on the safety of this medicine.

5. How to store Rotarix

Keep this vaccine out of the sight and reach of children.

Do not use this vaccine after the expiry date which is stated on the carton. The expiry date refers to the last day of that month.

Store in a refrigerator (2°C – 8°C).

Do not freeze.

Store in the original package in order to protect from light.

The vaccine should be used immediately after opening.

Do not throw away any medicines via wastewater or household waste. Ask your pharmacist how to throw away medicines your child no longer uses. These measures will help to protect the environment.

6. Contents of the pack and other information

What Rotarix contains

- The active substances are:

Human rotavirus RIX4414 strain (live, attenuated)* not less than 10^{6.0} CCID₅₀

*Produced on Vero cells

- The other ingredients in Rotarix are: sucrose (see also section 2, Rotarix contains sucrose), Disodium Adipate, Dulbecco's Modified Eagle Medium (DMEM), sterile water

What Rotarix looks like and contents of the pack

Oral suspension.

Rotarix is supplied as clear and colourless liquid in a single dose squeezable tube (1.5 ml).

Rotarix is available in a pack of 1, 10 or 50.

Not all pack sizes may be marketed.

Marketing Authorisation Holder

GlaxoSmithKline UK Limited
980 Great West Road
Brentford
Middlesex
TW8 9GS
United Kingdom

Manufacturer

GlaxoSmithKline Biologicals s.a.
Rue de l'Institut 89
B-1330 Rixensart
Belgium

This leaflet was last revised in January 2021

Other sources of information

The following information is intended for healthcare professionals only:

The vaccine is presented as a clear, colourless liquid, free of visible particles, for **oral** administration.

The vaccine is ready to use (no reconstitution or dilution is required).

The vaccine is to be administered **orally** without mixing with any other vaccines or solutions.

The vaccine should be inspected visually for any foreign particulate matter and/or abnormal physical appearance. In the event of either being observed, discard the vaccine.

Any unused vaccine or waste material should be disposed of in accordance with local requirements.

Instructions for administration of the vaccine:

Please read the instructions for use all the way through before starting to give the vaccine.

A What you need to do before giving Rotarix

- Check the expiry date.
- Check the tube has not been damaged nor is already open.
- Check the liquid is clear and colourless, without any particles in it.

If you notice anything abnormal, do not use the vaccine.

- This vaccine is given orally - straight from the tube.
- It is ready to use - you do not need to mix it with anything.

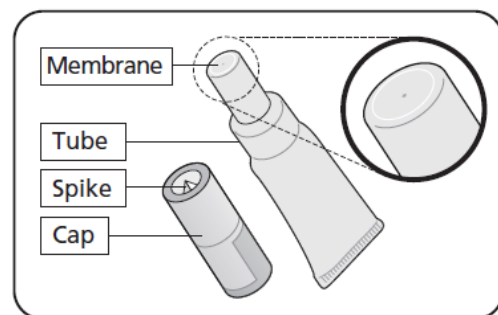

B Get the tube ready

1. Pull off the cap

- Keep the cap – you need this to pierce the membrane.
- Hold the tube upright.

2. Repeatedly flick the top of the tube until it is clear of any liquid

- Clear any liquid from the thinnest section of the tube by flicking just below the membrane.

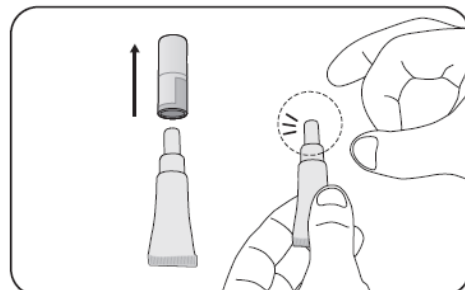

3. Position the cap to open the tube

- Keep the tube held upright.
- Hold the side of tube
- There is a small spike inside the top of the cap - in the centre.
- Turn the cap upside down (180°).

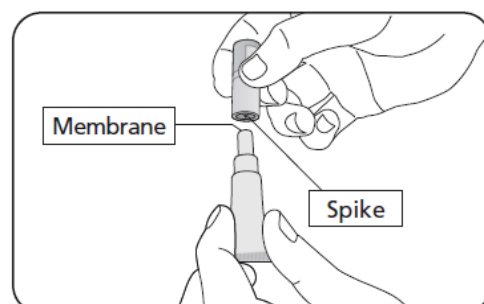

4. To open the tube

- You do not need to twist. Press the cap down to pierce the membrane.
- Then lift off the cap.

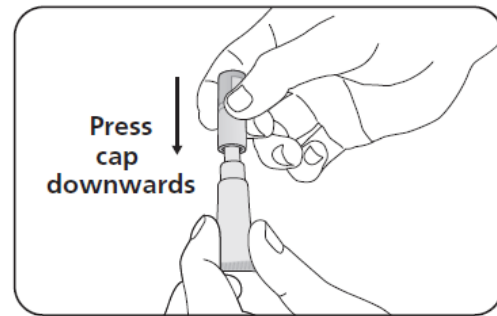

C Check the tube has opened correctly

1. Check the membrane has been pierced

- There should be a hole at the top of the tube.

2. What to do if the membrane has not been pierced

- If the membrane has not been pierced return to section B and repeat steps 2, 3 and 4.

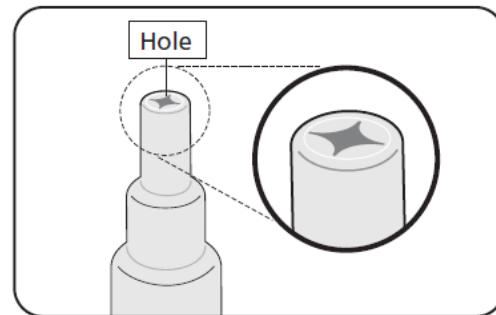

D Give the vaccine

- Once the tube is open check the liquid is clear, without any particles in it.
If you notice anything abnormal, do not use the vaccine.
- Give the vaccine straight away.

1. Position the child to give the vaccine

- Seat the child leaning slightly backwards.

2. Administer the vaccine

- Squeeze the liquid gently into the side of the child's mouth - towards the inside of their cheek.
- You may need to squeeze the tube a few times to get all of the vaccine out - it is okay if a drop remains in the tip of the tube.

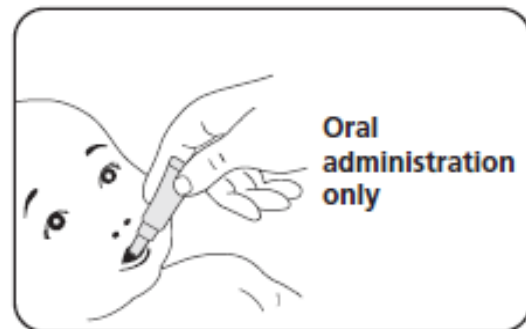

Discard the empty tube and cap in approved biological waste containers according to local regulations.